

INDIANA

JREG 4so/50

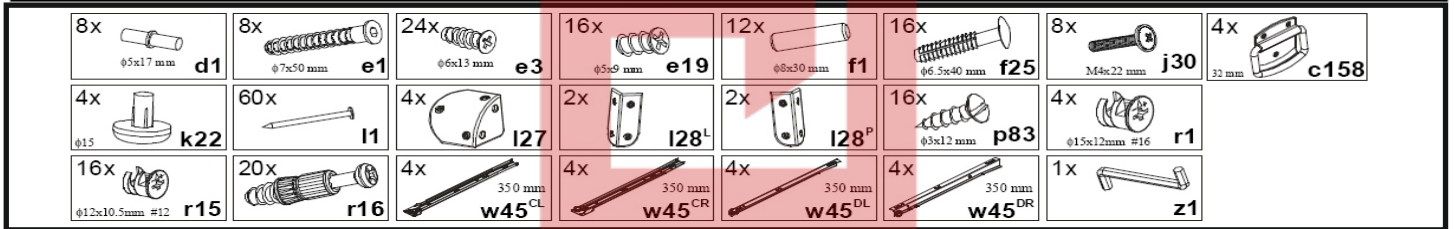

A	C	B	D
1	1916x370	S31-111	1/3
2	1916x370	S31-112	1/3
3	500x395	S31-204	2/3
4	500x395	S31-209	2/3
5	467x370	S31-303	1/3
6	467x370	S31-304	1/3
7	496x196	S31-011	3/3
8	496x196	S31-012	3/3
9	496x196	S31-008	3/3
10	350x140	S31-504	1/3
11	350x140	S31-505	1/3
12	418x140	S31-506	1/3
13	429x348	S31-903	1/3
14	1942x493	S31-911	1/3

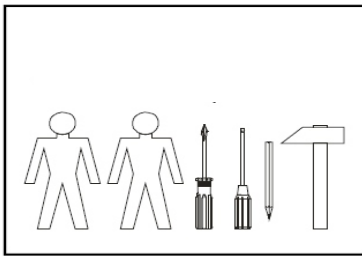
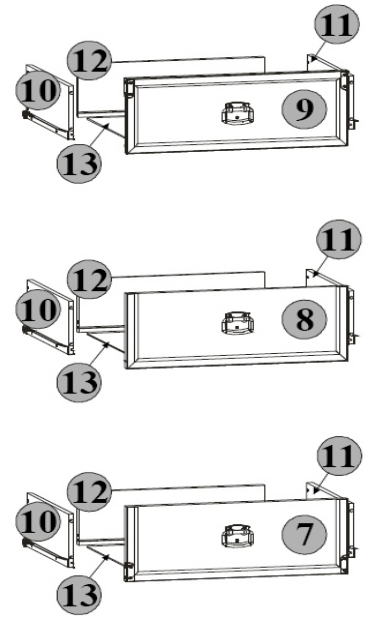
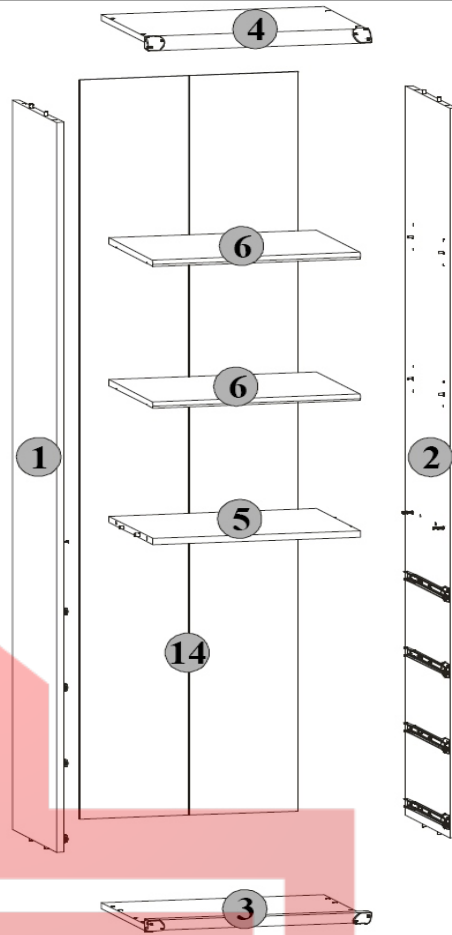

1 JREG 4so/50

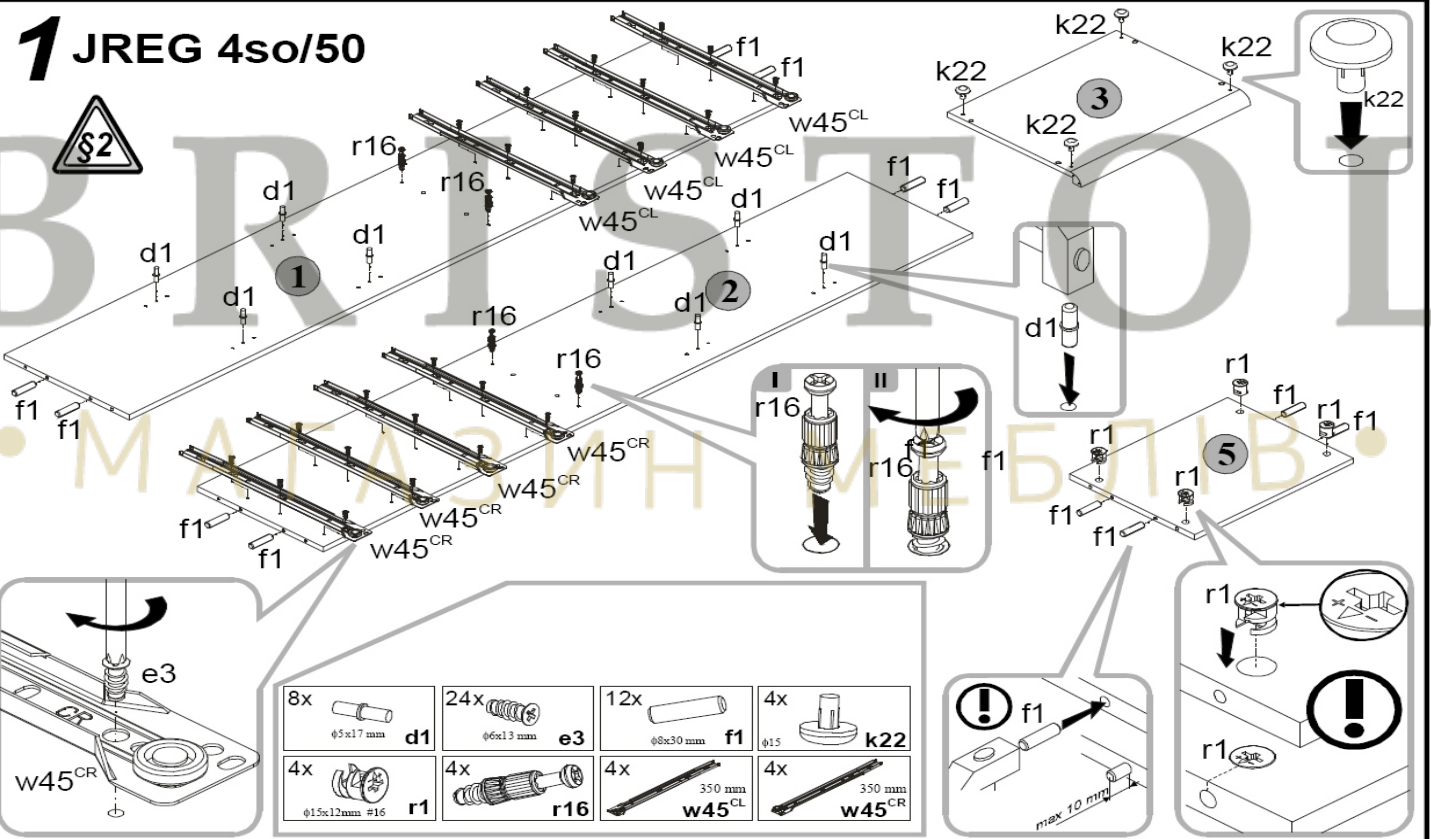

2 JREG 4so/50

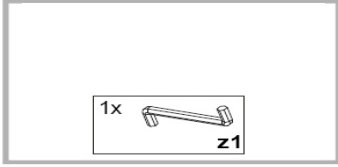
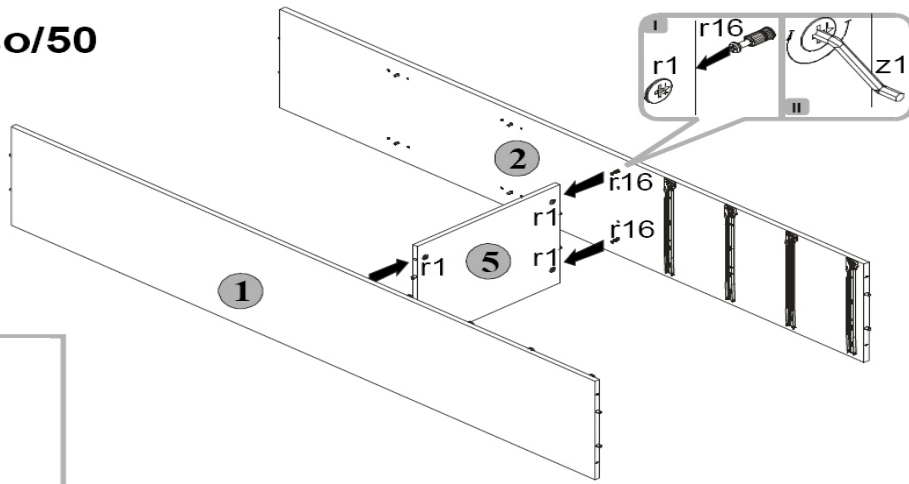

3 JREG 4so/50

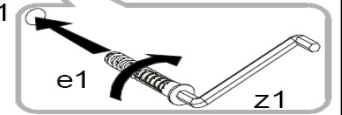
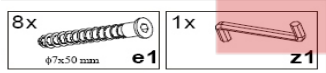
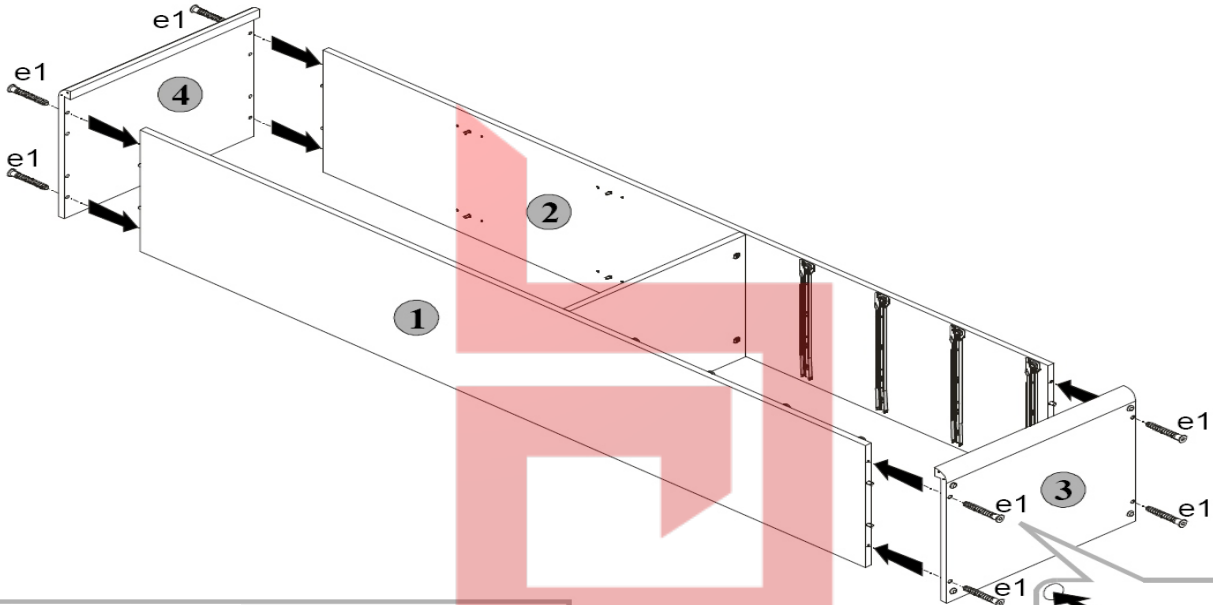

4 JREG 4so/50

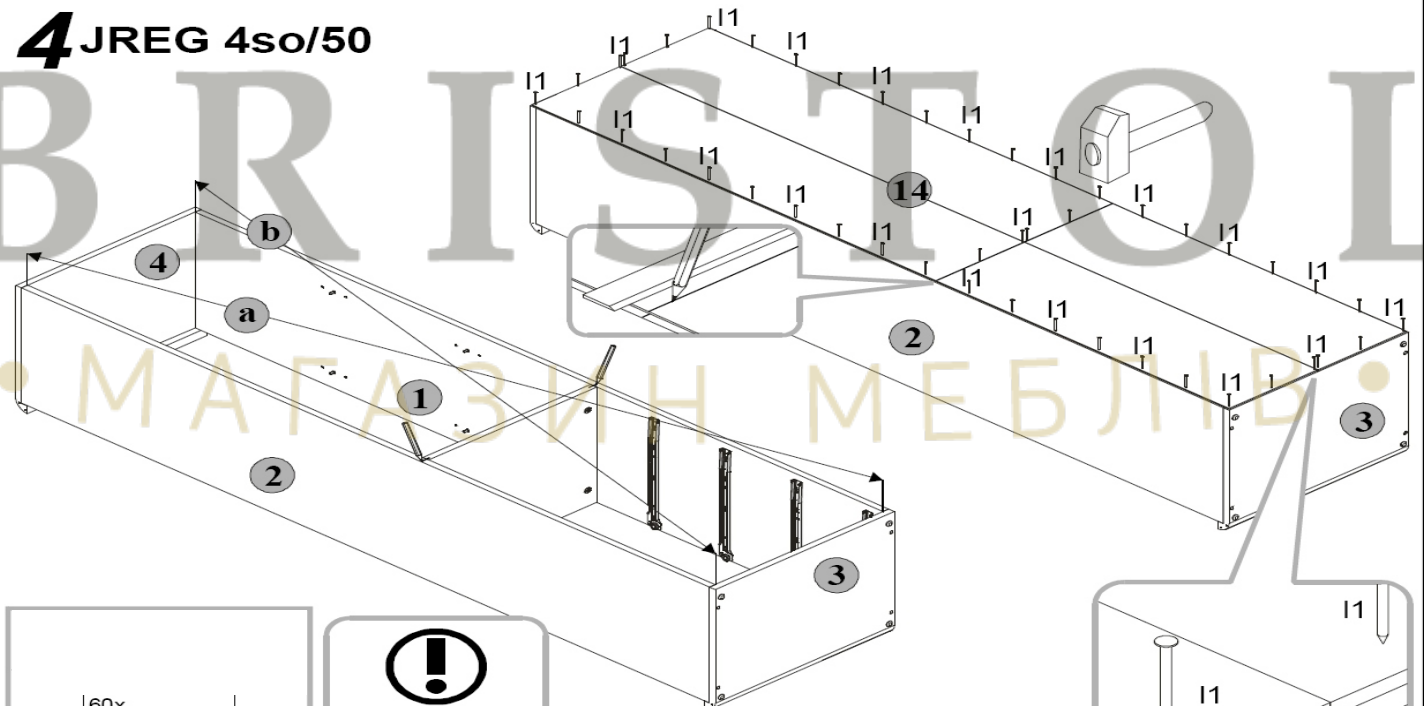

5 JREG 4so/50

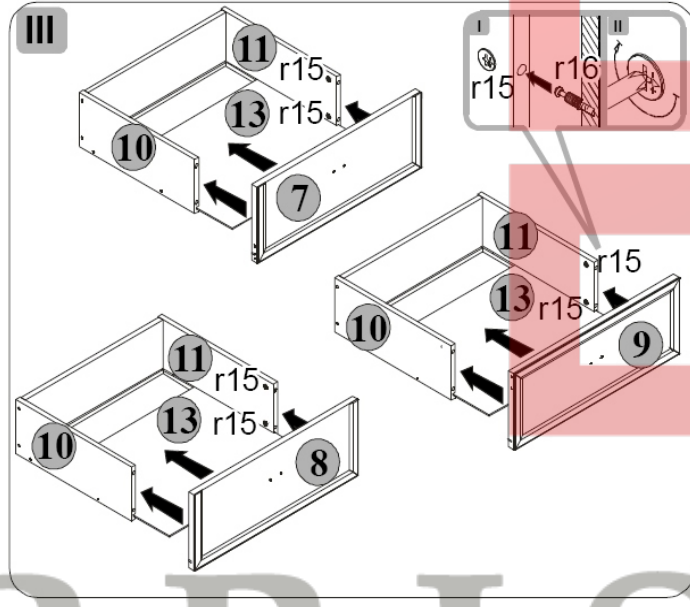
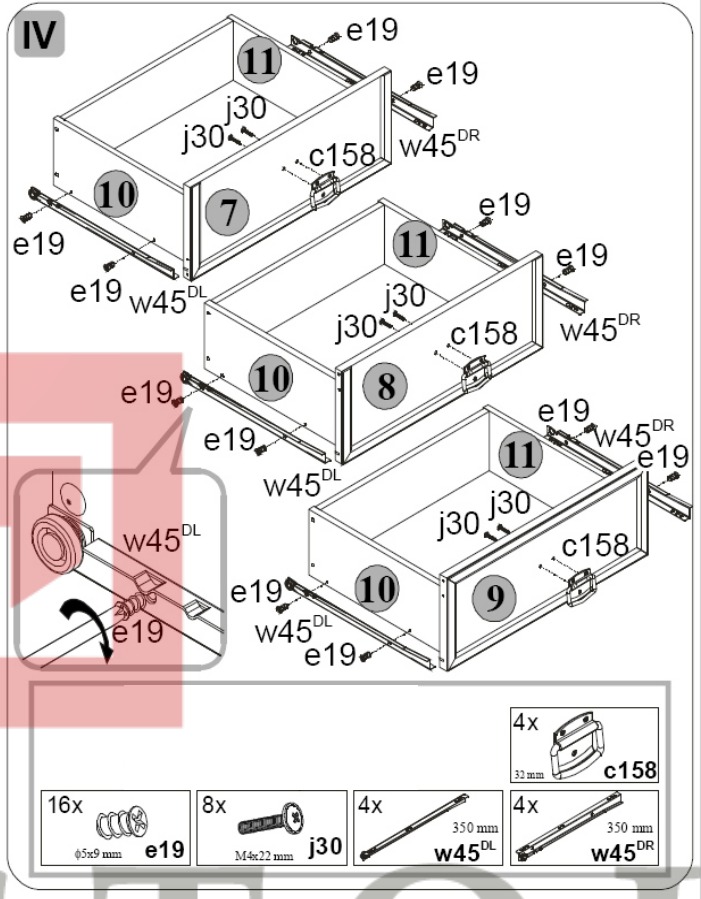
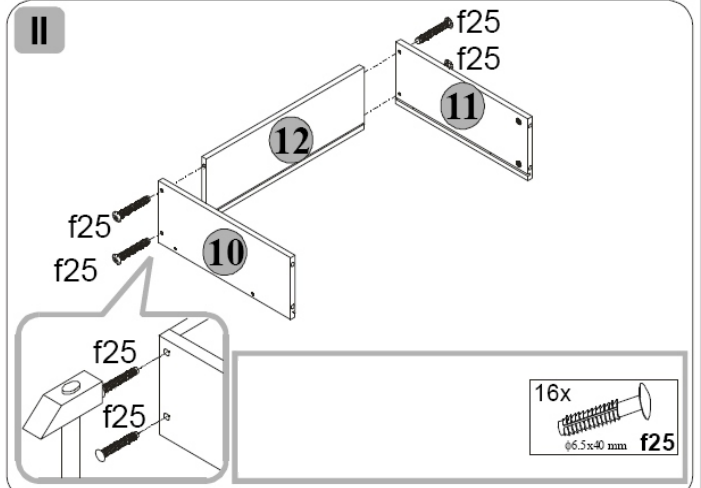
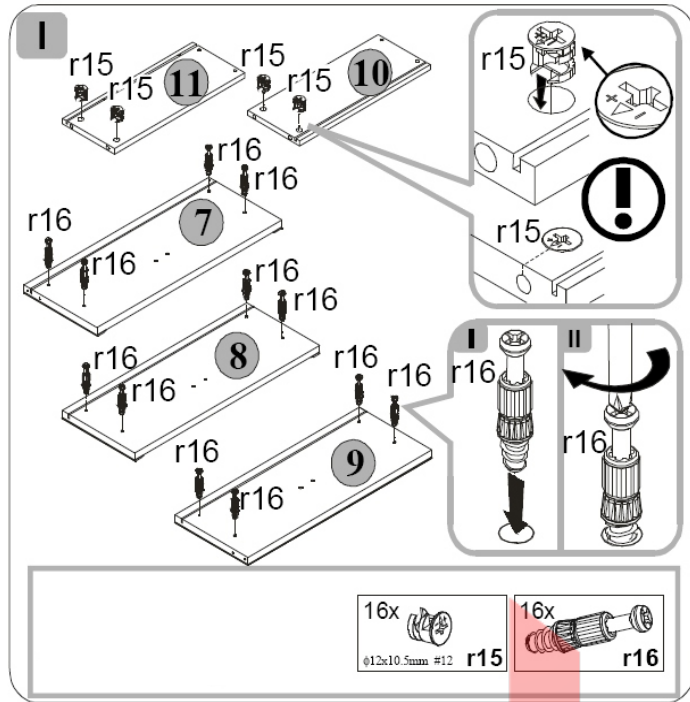

6 JREG 4so/50

