

# CAPS

# S153-KOM4S/80

A	B	C	D	
1	S153-0001	733	188	1/2
2	S153-0002	733	188	1/2
3	S153-1101	843	399	1/2
4	S153-1102	843	399	1/2
5	S153-2201	804	403	1/2
6	S153-3301	738	383	1/2
7	S153-571	188	100	2/2
8	S153-572	70	100	2/2
9	S153-9901	807	381	1/2
10	S153-9902	700	348	1/2
11	ZS2-511	350	120	1/2
12	ZS2-512	350	120	1/2
13	ZS2-5583	689	120	1/2
14	LH-777	777	14	1/2

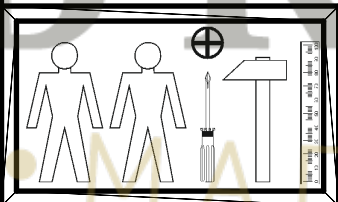
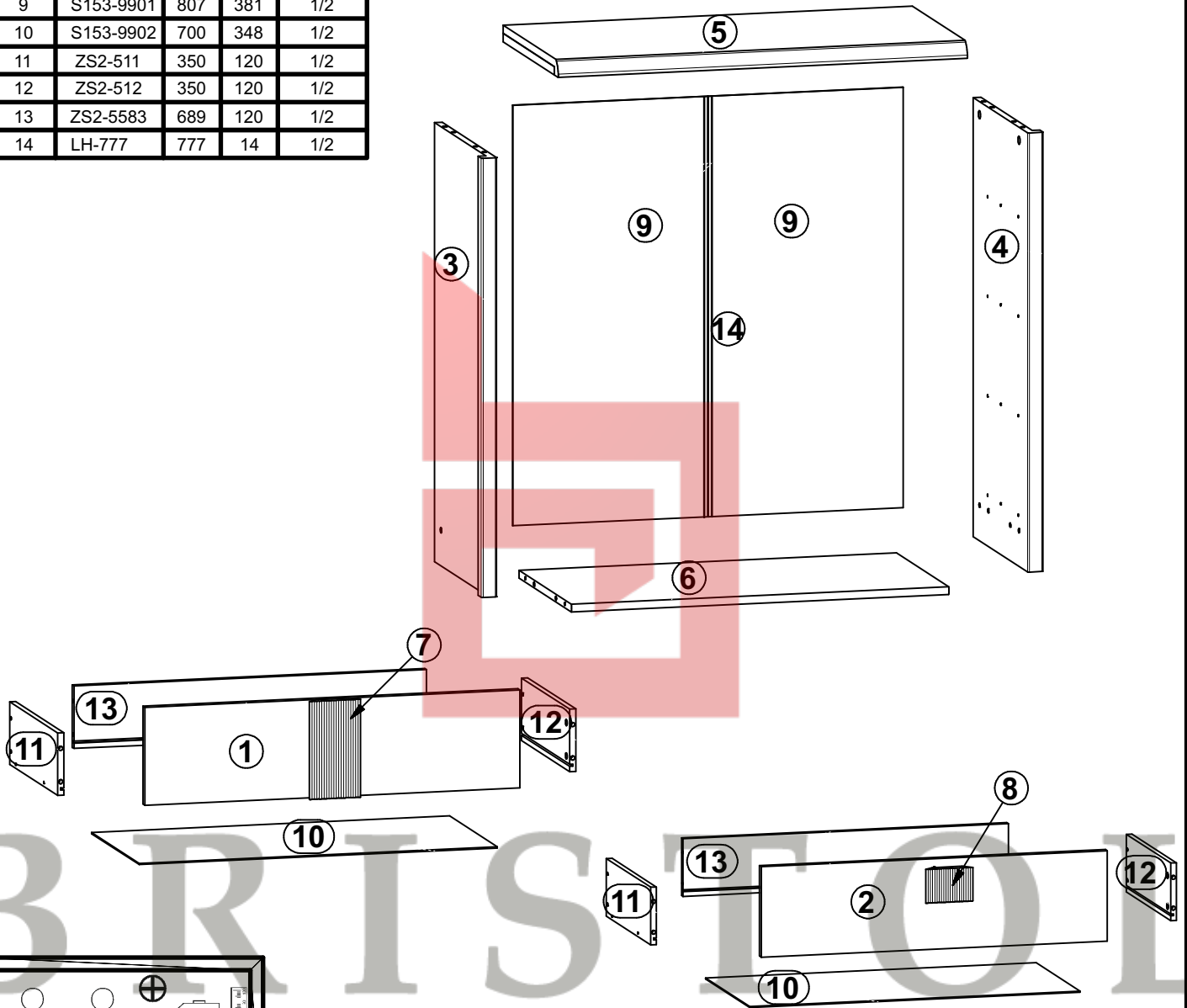
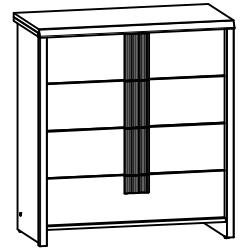

4x φ7x50 mm e1	16x φ5x9 mm e19	24x φ6x13 mm e3	8x φ8x30 mm f1	16x φ6.5x40 mm f25	4x k1	35x l1	8x φ3.5x16 mm p25	8x φ4x22 mm p60
4x φ1.5x12mm #16 r1	16x φ12x10.5mm #12 r15	20x r42	4x 333 mm t19	4x 350 mm w45\CL	4x 350 mm w45\CR	4x 350 mm w45\DL	4x 350 mm w45\DR	1x z1
1x n26\1	1x φ3.5x16 mm p38	4x s1	2x ø16 s2					

1 

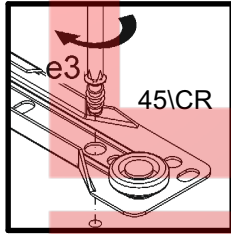
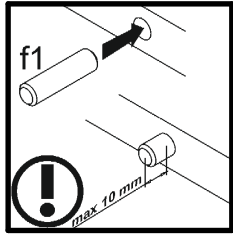
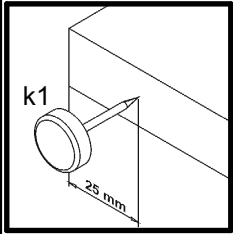
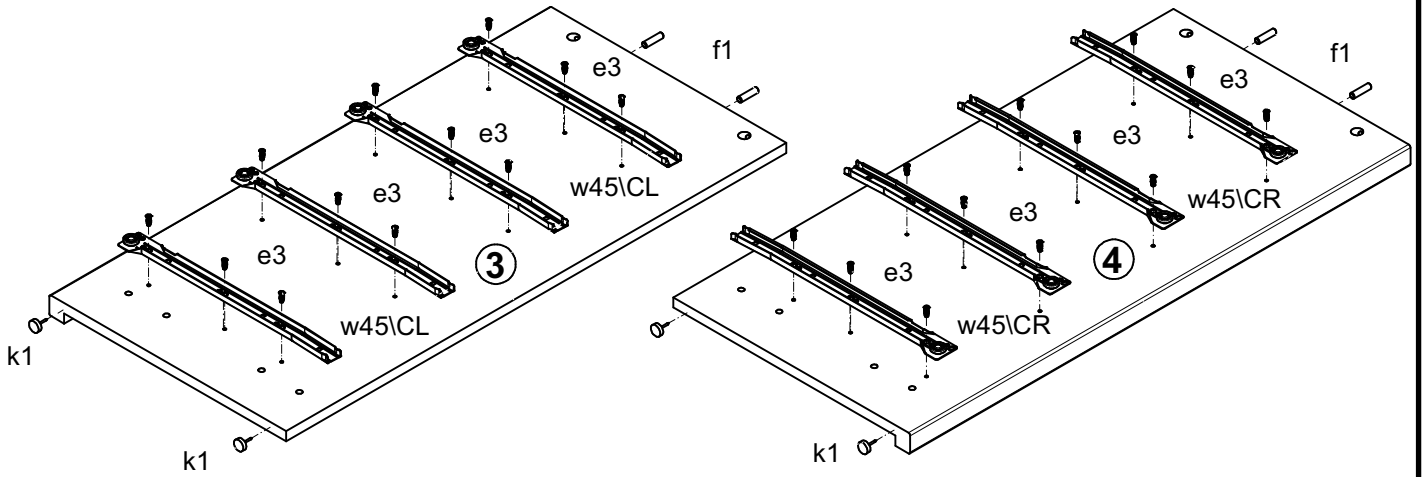

2 

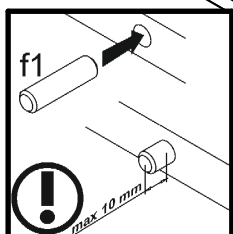
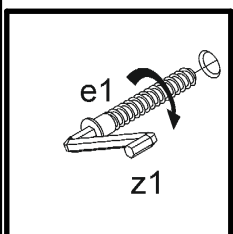
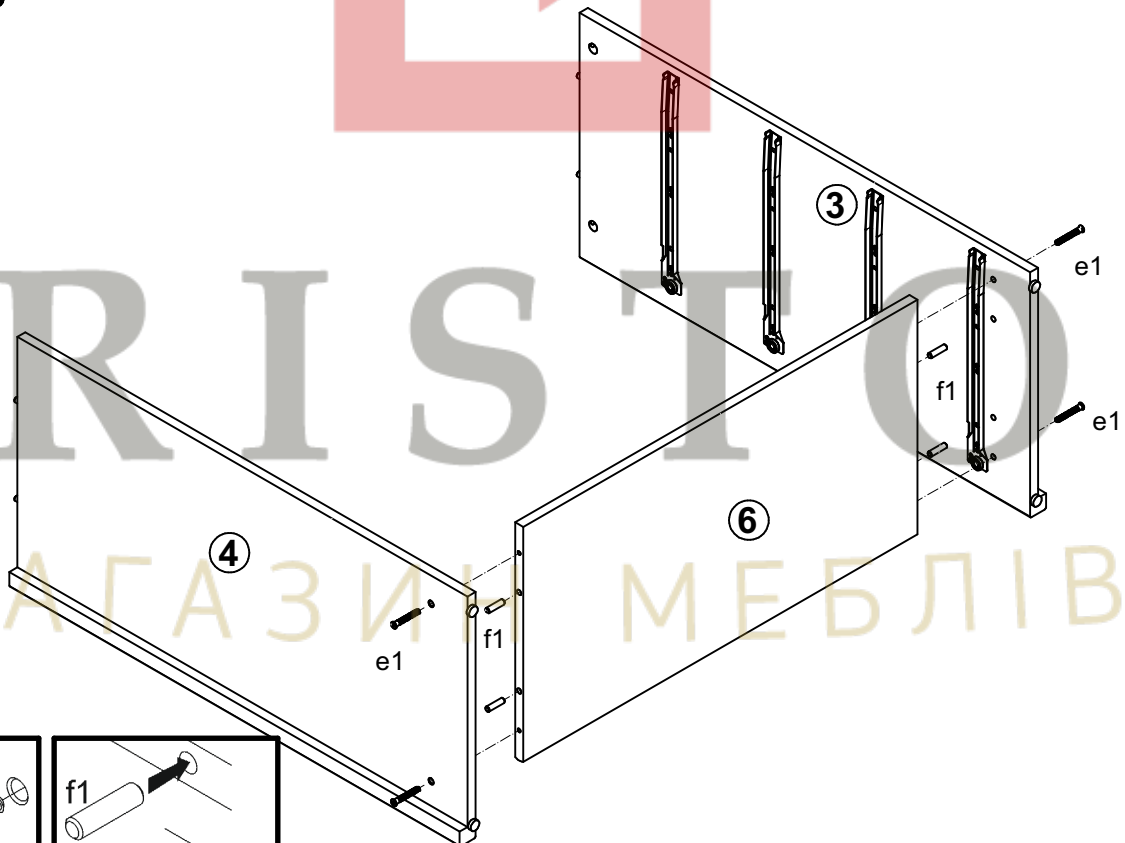

# 3

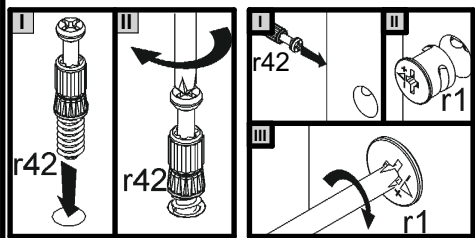
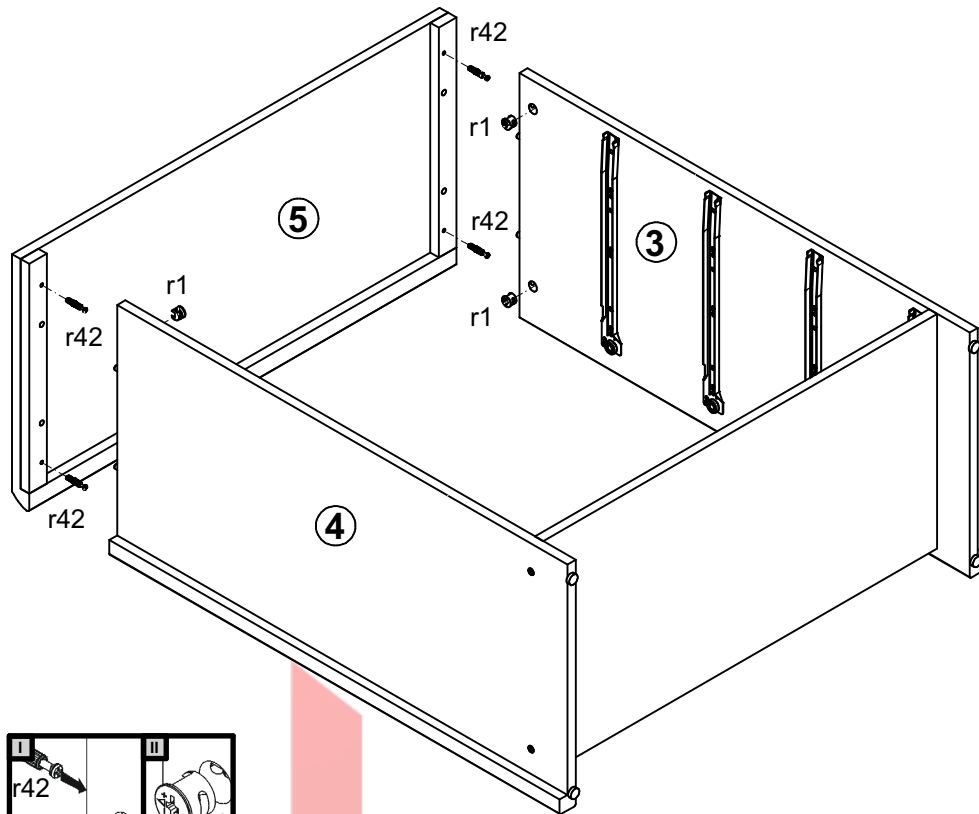

# 4

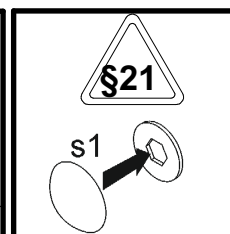
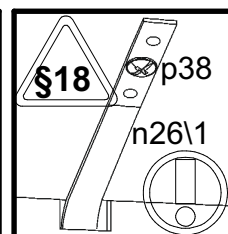
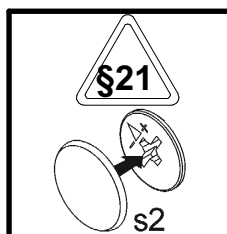
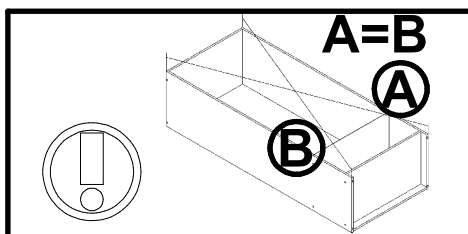
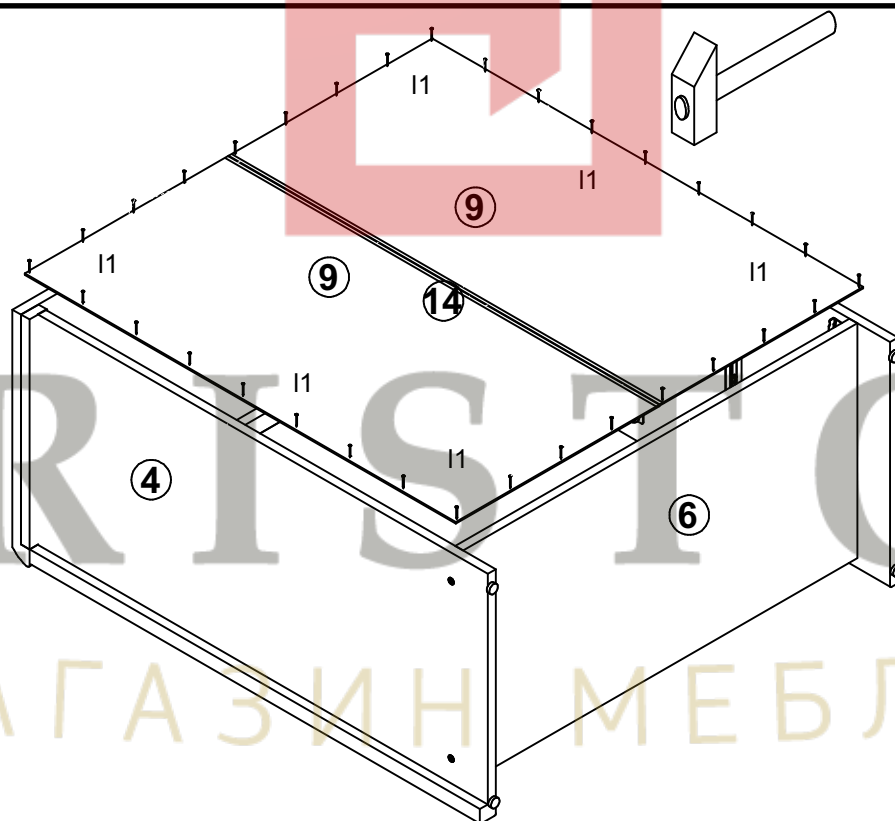

# 5

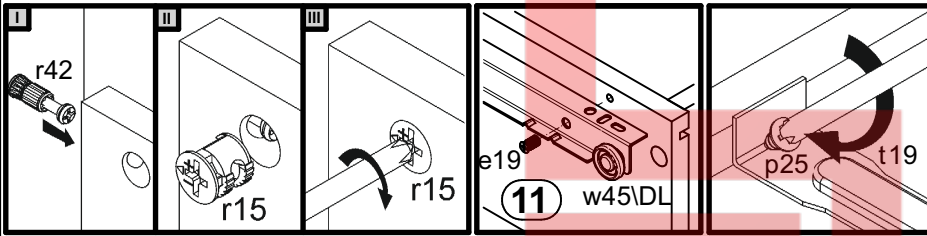
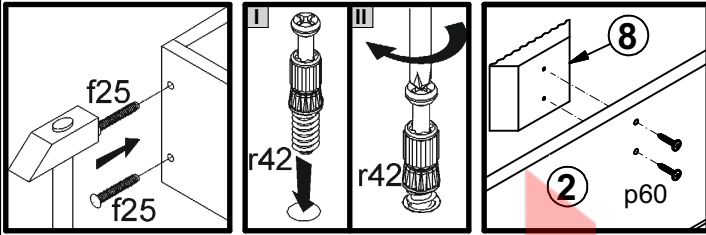
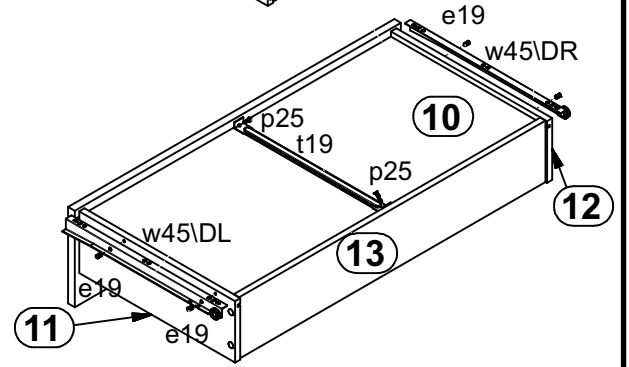
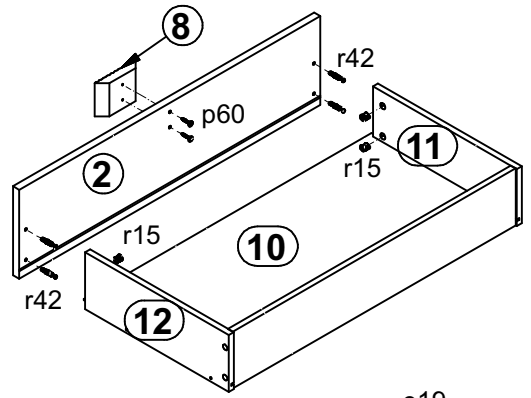
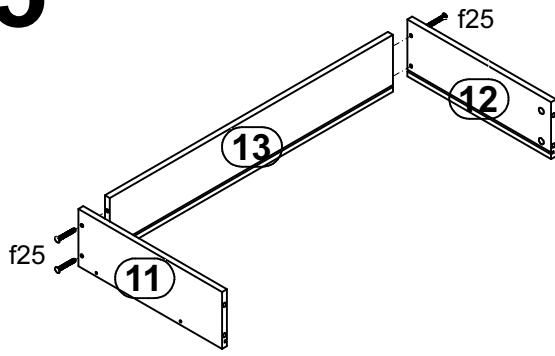

# 6

