

# ИНСТРУКЦИЯ МОНТАЖА

PIKO

## Комод 2D4S

Габариты, см

выс.	шир.	гл.
90	145	45

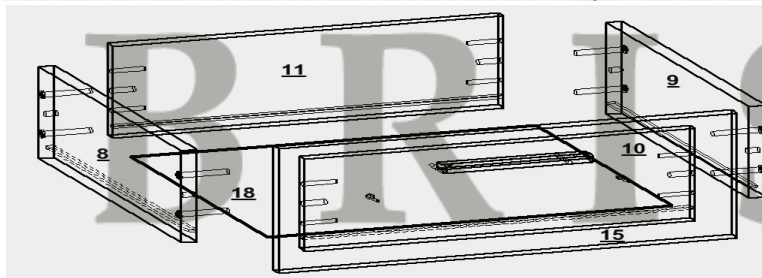
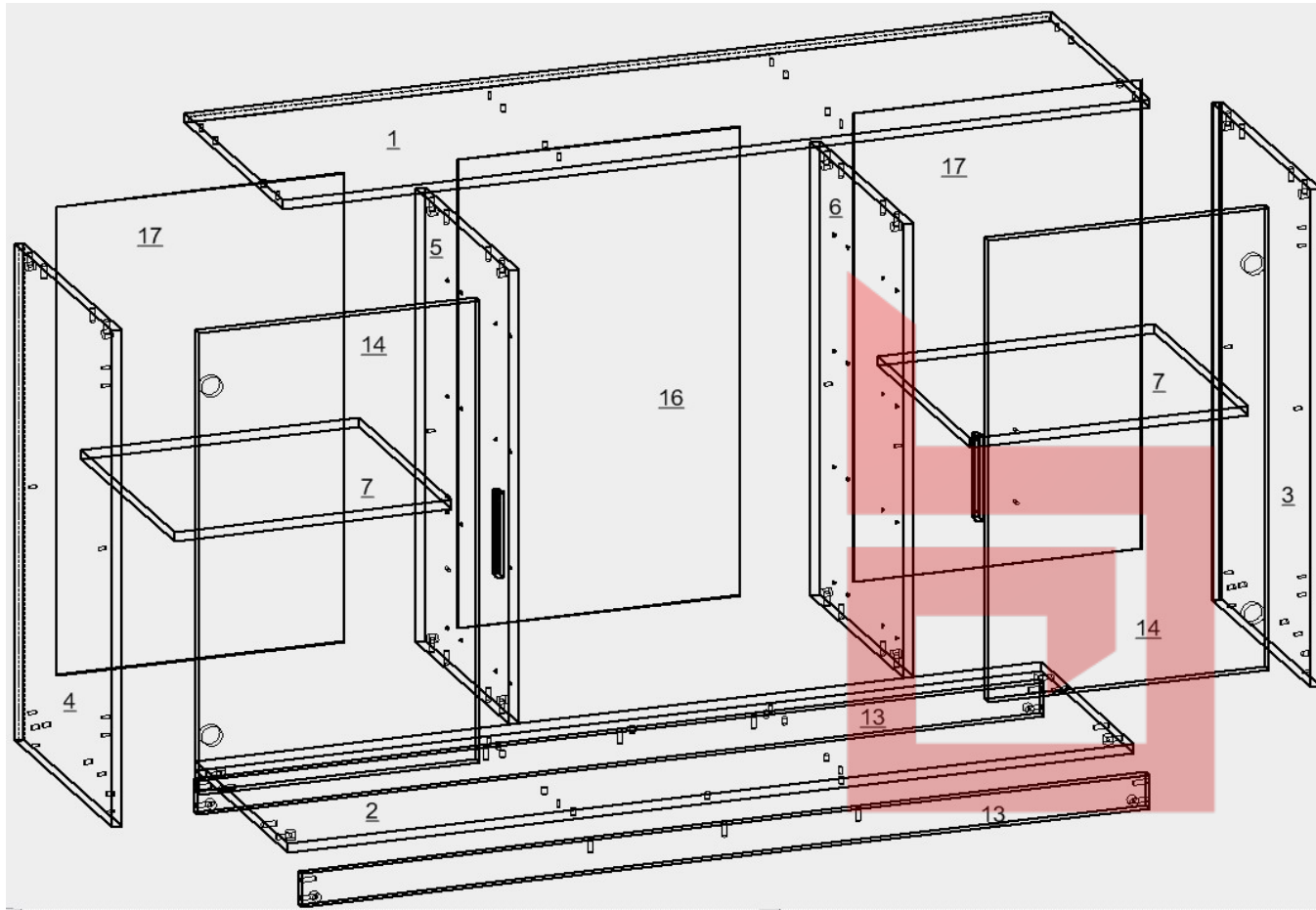
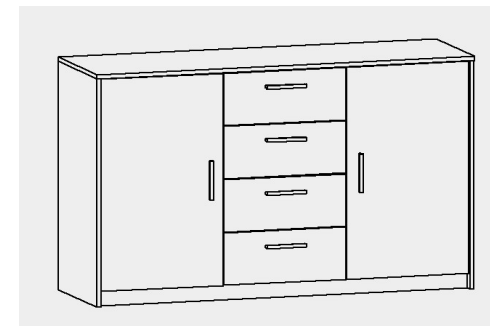

№	код	Размер		шт.	
1	P-204	1450	452	16	1
2	P-307	1416	427	16	1
3	P-107	884	450	16	1
4	P-108	884	450	16	1
5	P-109	808	427	16	1
6	P-110	808	427	16	1
7	P-308	464	427	16	2
8	P-505	400	150	16	4
9	P-506	400	150	16	4
10	P-507	399	150	16	4
11	P-508	399	150	16	4
12	P-005	203	468	16	3
13	P-404	60	1416	16	2
14	P-004	821	469	16	2
15	P-005	203	468	16	1
16	P-606	833	472	3	1
17	P-607	833	481	3	2
18	P-608	413	382	3	4

• МАГАЗИН МЕБЛІВ •